

LIFT WELL PLAN (Center Opening Doors)

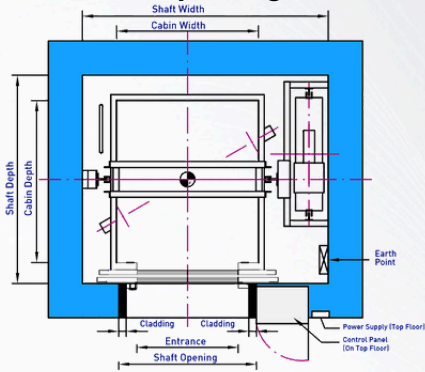

Telescopic Side Opening Doors

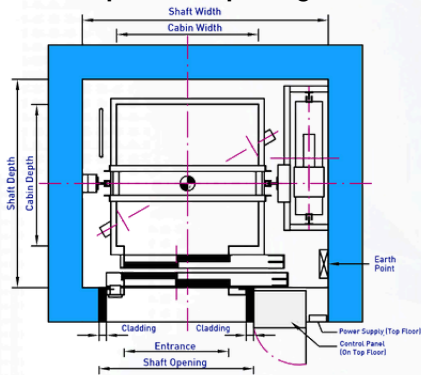

LIFT WELL ELEVATION

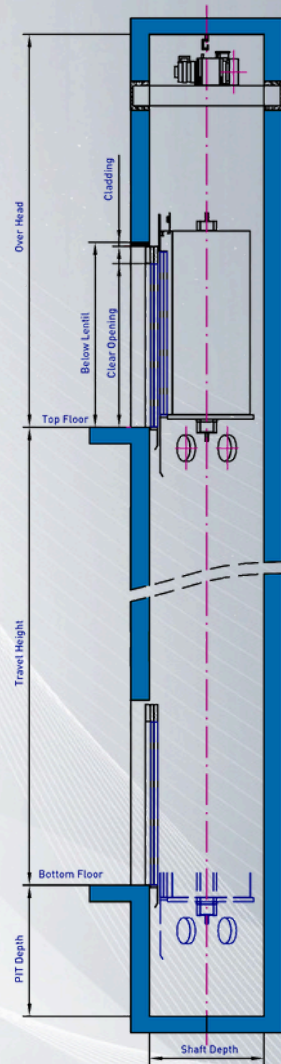

CAPACITY		CAR INSIDE (Center Opening)		LIFT WELL (Center Opening)		CAR INSIDE (Side Opening)		LIFT WELL (Side Opening)		ENTRANCE	SHAFT OPENING	
PERSONS	KGs.	WIDTH	DEPTH	WIDTH	DEPTH	WIDTH	DEPTH	WIDTH	DEPTH			
272	5340	408	800	1600	1350	800	900	1400	1400	700	1040	
			1000	900	1600	1350	1000	1100	1550	1400	700	1040
			1000	1100	1800	1500	1000	1000	1550	1550	800	1140
			1100	1000	1800	1450	1100	1050	1650	1450	800	1140
7	476		1200	1050	1800	1450	1200	1300	1800	1500	800	1140
			1100	1300	1800	1650	1100	1200	1700	1700	800	1140
8	544		1200	1200	1800	1600	1200	1350	1800	1600	800	1140
			1200	1350	1800	1800	1200	1300	1800	1800	800	1140
10	680		1250	1300	1850	1750	1250	1350	1850	1750	800	1140
			1350	1350	2000	1800	1350	1750	1900	1800	900	1240
13	884		1400	1750	2200	2100	1400	1800	2050	2150	1000	1340
			1500	1800	2200	2150	1500	1950	2050	2200	1000	1340
15	1020		1500	1800	2200	2100	1500	1950	2050	2200	1000	1340
			1500	1950	2250	2350	1500		2150	2400	1000	1340
16	1088											

LIFT SPEED METERS/SEC.	PIT DEPTH	OVER HEAD MINIMUM	CLEAR(DOOR) OPENING	BELOW LENTIL FROM FINISHED FLOOR LEVEL*
0.7 TO 1.0	1600	4800	2000	2260
1.25	1600	5000	2100	2360
1.5	1800	5500	2200	2460

NOTE

1. All dimensions are in millimeters.
2. All dimensions are for clear finished lift wells after plastering.
3. All walls minimum 150 RCC or 230 brick (hoist way front wall 230 brick preferred).
4. Power supply 400 volts, 3 phase, 4 wires, 50Hz and 230 volts 1 phase terminating in a MCCB/ELCB switch to be provided by clients.
5. For specific requirements our local representative will be happy to work with you in a preparation of working drawings.

NOTE: The indicated sizes are approximate - for layout drawings, please contact with Hexa Lifts

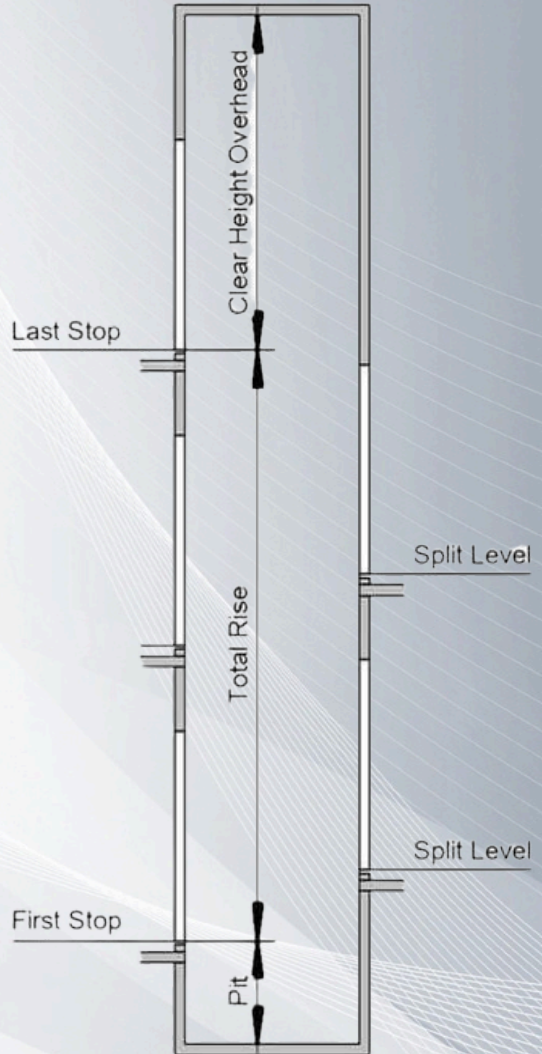
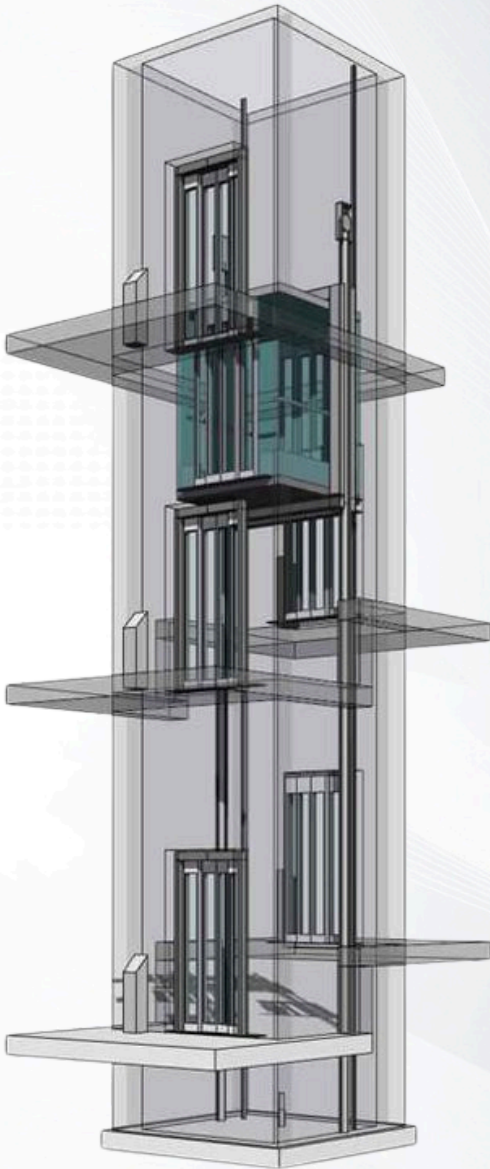

NOTE: The indicated sizes are approximate - for layout drawings, please contact with Hexa Lifts



NOTE: The indicated sizes are approximate - for layout drawings, please contact with Hexa Lifts